

Skolah



PRIMARY AND
SECONDARY
EDITION

Number 1

preferred choice of custom made
school uniform manufacturer in
Malaysia by *school votes*

CATALOG 2022





Button shirt



T-shirt



Polo Shirt



Short Pant



Long Pant



CONTENT

03 - 04	Material
05-08	Button Shirt
09-12	T-Shirt
13-16	Polo Shirt
17-20	Short Pant
21-24	Long Pant
25-26	Customized Process

Material

The application of our fabric is mostly for shirt and uniform.

1. TC Drill



- Polyester (65%), Cotton (35%)
- 230 g/m²
- Common used in short pants, skorts

TC Drill is a fabric made of both the artificial polyester and the natural cotton. As cotton/polyester composition is 35% of cotton and 65% of polyester. The blend is perfect for clothing as it brings both benefits of the two fabrics together. The fabric thus remains lightness and coolness of the cotton while still adding the strength and durability of the polyester. TC Drill material can be wash easily and show very good breathable and durable properties.

2. Polyester



- Polyester (100%)
- 175 g/m²
- Common used in short pants, skorts

Polyester is a generalised term for any fabric or textile, which is made using polyester yarns or fibres. 100% polyester is no mixing of any cotton material. It is such a popular choice for apparel because polyester fibres are thermoplastic, or heat-sensitive. They are also highly stain-resistant, so great for cleaning. Polyester fabric is easy to look after and it can be washed and dried at home.

3. 20 TC Pique (PK)



- Polyester (65%), Cotton (35%)
- 220 g/m²
- Common used in polo shirt

Pique's weave features cotton yarn characterised by raised parallel cords or fine ribbing. This gives the material a subtle pattern and texture – which can only be seen up close. It's breathable, durable and easily cared for and has excellent give and comfort. Its breathable nature also ensures that any wearers of pique stay cool. Furthermore, the textured weave is great at hiding all those perspiration stains.

4. 26 TC Single Jersey



- Polyester (65%), Cotton (35%)
- 175 g/m²
- Common used in T-shirt

This material is basic fabric and common used in T-shirt. It is light weight, soft & smooth on the skin. It is good sweat absorbent and have quick dry & cool features. Single jersey is best material for outdoor and indoor wear.

5. TC



- Polyester (65%), Cotton (35%)
- 110 g/m²
- Common used in button shirt

TC is Teton Cotton as polyester/cotton blended. TC fabrics are welcomed by people because of their excellent strength, durability, wrinkle resistance, high color fastness and good hygiene characteristics. It is often used for button shirt. TC material has good water absorption and high durability.



SKOLLAH



Button shirt

Material: TC

- Polyester (65%), Cotton (35%)

Primary size	12 - 22
Secondary size	S - XL

Easy care High durability

Quick dry Excellent strength

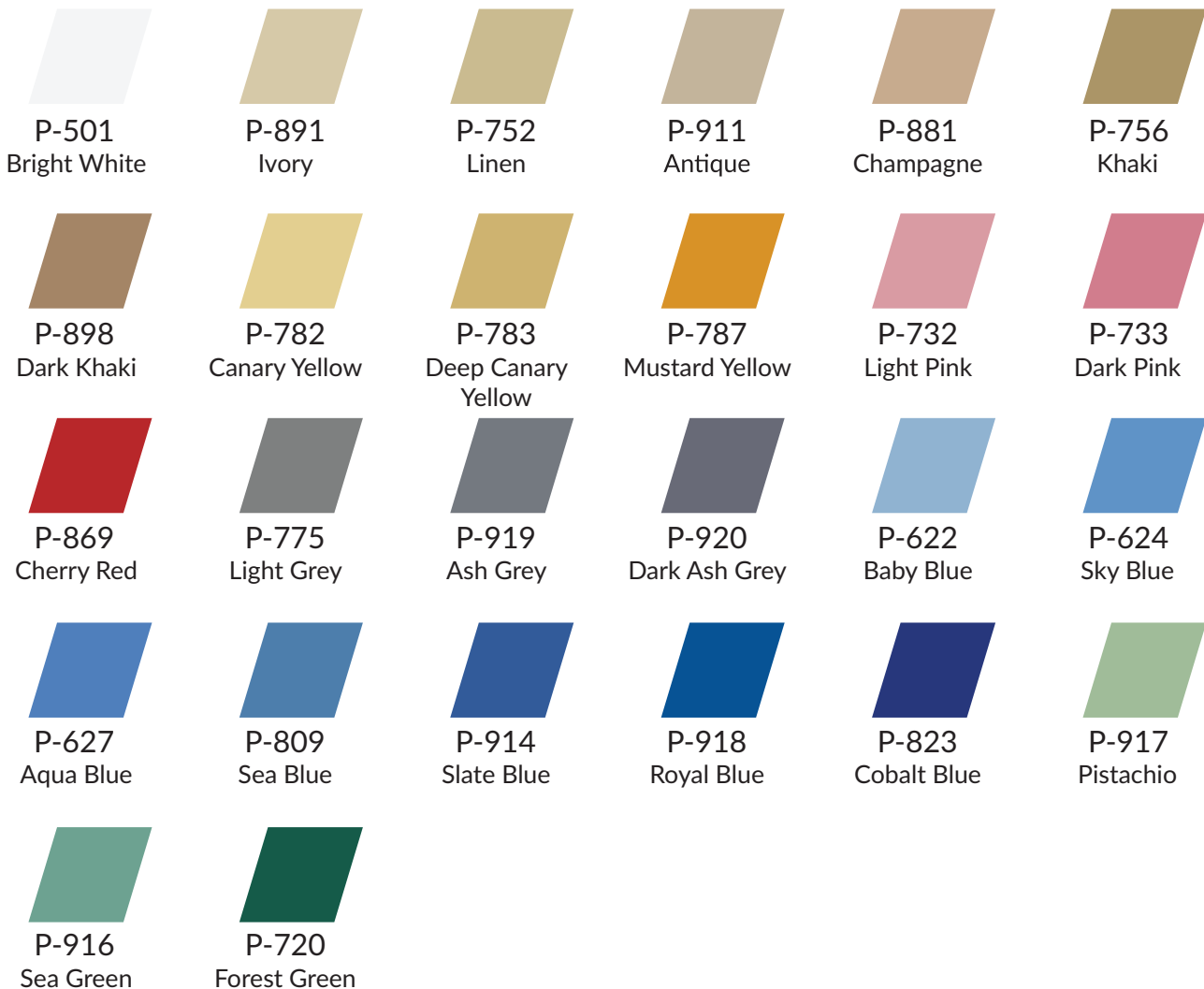

Button Shirt

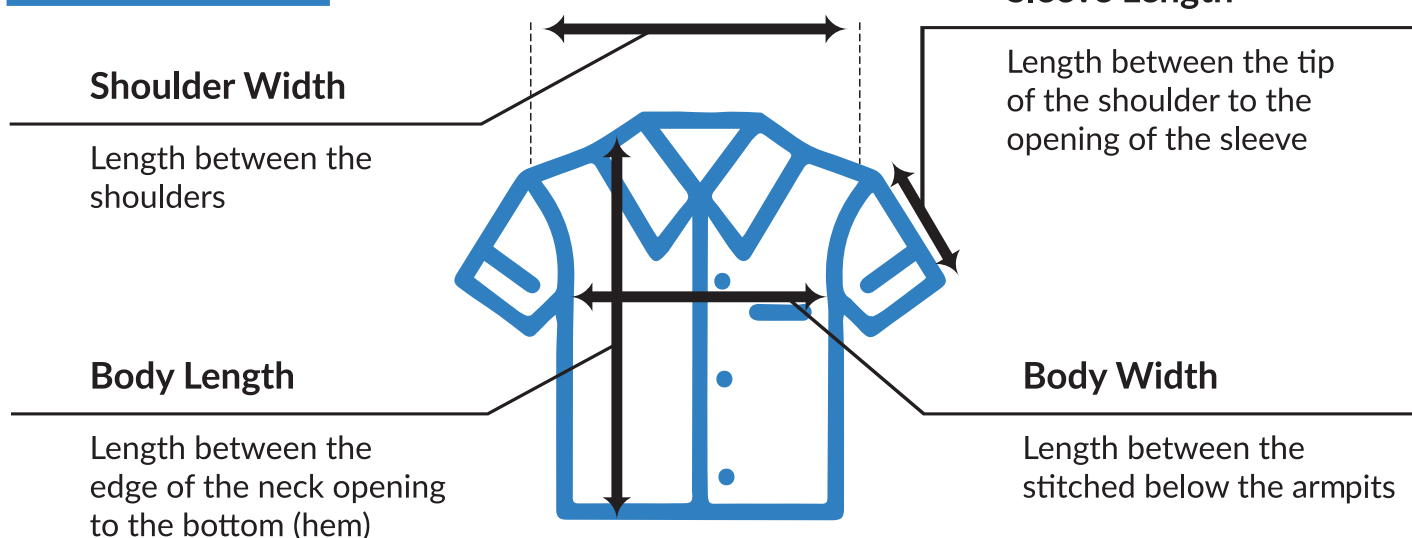

SKOLAH Clothing Guide

Primary Size Cutting

	<i>Measurement (inch)</i>										
Size	12	13	14	15	16	17	18	19	20	21	22
Shoulder	14 ^{1/2}	14 ^{1/2}	14 ^{3/4}	15	15 ^{1/4}	15 ^{1/2}	15 ^{3/4}	16	16 ^{1/4}	16 ^{1/2}	17
Chest	30	31	32	34	35	36	37	38	39	40	41
Body Length (Front)	19	20	21	22	23	24	25	25 ^{1/2}	26	26 ^{1/2}	27
Sleeve Length	5	5 ^{1/2}	6	6	6 ^{1/2}	6 ^{1/2}	7	7 ^{1/2}	8	8 ^{1/2}	9

Secondary Size Cutting

	<i>Measurement (inch)</i>			
Size	S	M	L	XL
Shoulder	18	19	20	21
Chest	43	46	49	51
Body Length	28	29	30	31
Sleeve Length (Short)	10 ^{1/2}	11	11 ^{1/2}	11 ^{1/2}
Sleeve Length (Long)	23	23	24	24

*Size might be different +/- 0.5 due to manual measurement

COMFORTABLE





T-shirt

Material: 26 TC Single Jersey

- Polyester (65%), Cotton (35%)

Primary size	24 - 38
Secondary size	S - 5XL



Quick dry & cool

Sweat absorbent

Durable and soft

Lasting colour



1
White



2
Beige



3
Light Yellow



4
Bright Yellow



5
Pearl Pink



6
Light Purple



7
Sky Blue



8
Lime Green



9
Golden Yellow



10
Orange



11
Dark Orange



12
Fuschia



13
Ash Grey



14
Light Grey



15
Dark Grey



16
Sea Blue



17
Berry Red



18
Maroon Red



19
Earth Green



20
Teal



21
Emerald Green



22
Royal Blue



23
Purple



24
Navy Blue



25
Dark Brown



26
Black



29
Melange Light
Grey



30
Melange Dark
Grey

T-Shirt

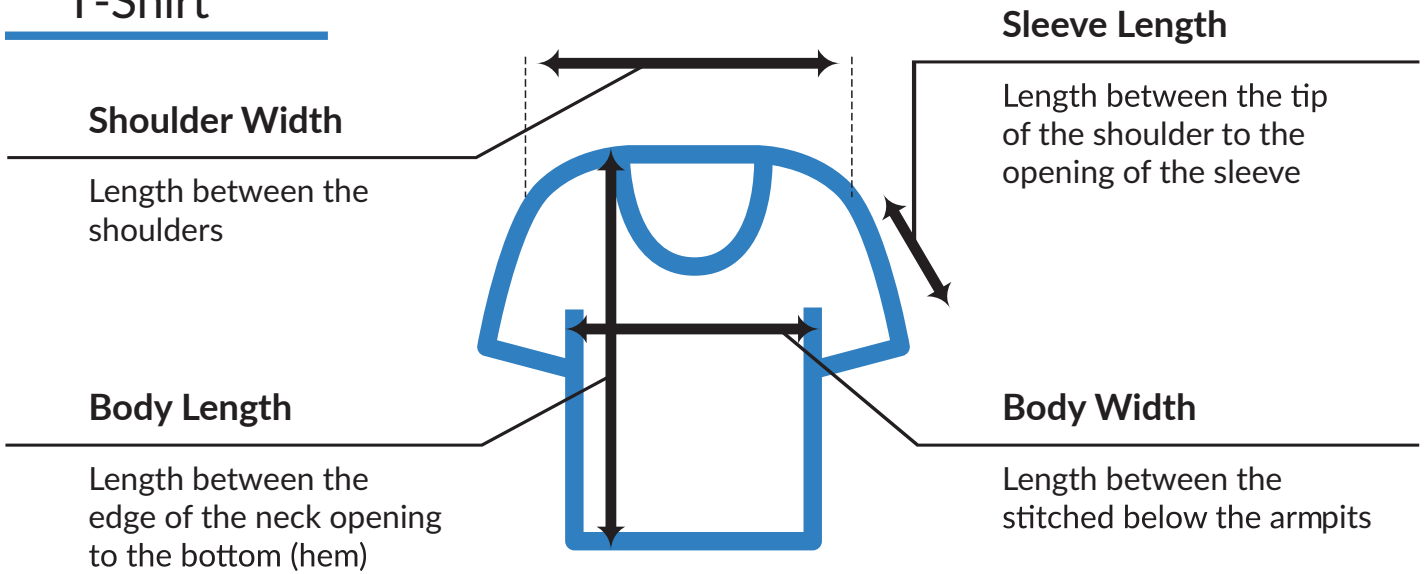

SKOLAH Clothing Guide

Primary Size Cutting

Measurement (inch)

Size	24	26	28	30	32	34	36	38
Shoulder	11	12	12 ^{1/2}	13	14	15	16	17
Chest	24	25 ^{1/2}	27 ^{1/2}	29	31	33	35	37
Body Length (Front)	16 ^{1/2}	17 ^{1/2}	18	20	21	22	23 ^{1/2}	26 ^{1/2}
Sleeve Length (Short)	5	5 ^{1/2}	6	6	6 ^{1/2}	6 ^{1/2}	7	7 ^{1/2}
Sleeve Length (Long)	14	14 ^{1/2}	15	15 ^{1/2}	16	17	18	19

Secondary Size Cutting

Measurement (inch)

Size	40/S	42/M	44/L	46/XL	48/2XL	50/3XL	52/4XL	54/5XL
Shoulder	17	18 ^{1/2}	19	20	21	21 ^{1/2}	23	24
Chest	39	41	43	45	47	48 ^{1/2}	50 ^{1/2}	52 ^{1/2}
Body Length	27	28	29 ^{1/2}	30	31	31 ^{1/2}	33	36
Sleeve Length (Short)	8	8 ^{1/2}	9	9 ^{1/2}	10	10	10 ^{1/2}	11 ^{1/2}
Sleeve Length (Long)	20	21	21 ^{1/2}	22	22 ^{1/2}	23 ^{1/2}	25	26

*Size might be different +/- 0.5 due to manual measurement



COMFORTABLE





Polo shirt

Material: 20TC Pique (PK)

- Polyester (65%), Cotton (35%)

Primary size	24 - 38
Secondary size	S - 5XL

Shrink resistant

Crumple resistant

Lasting colour

Least sweat absorbent

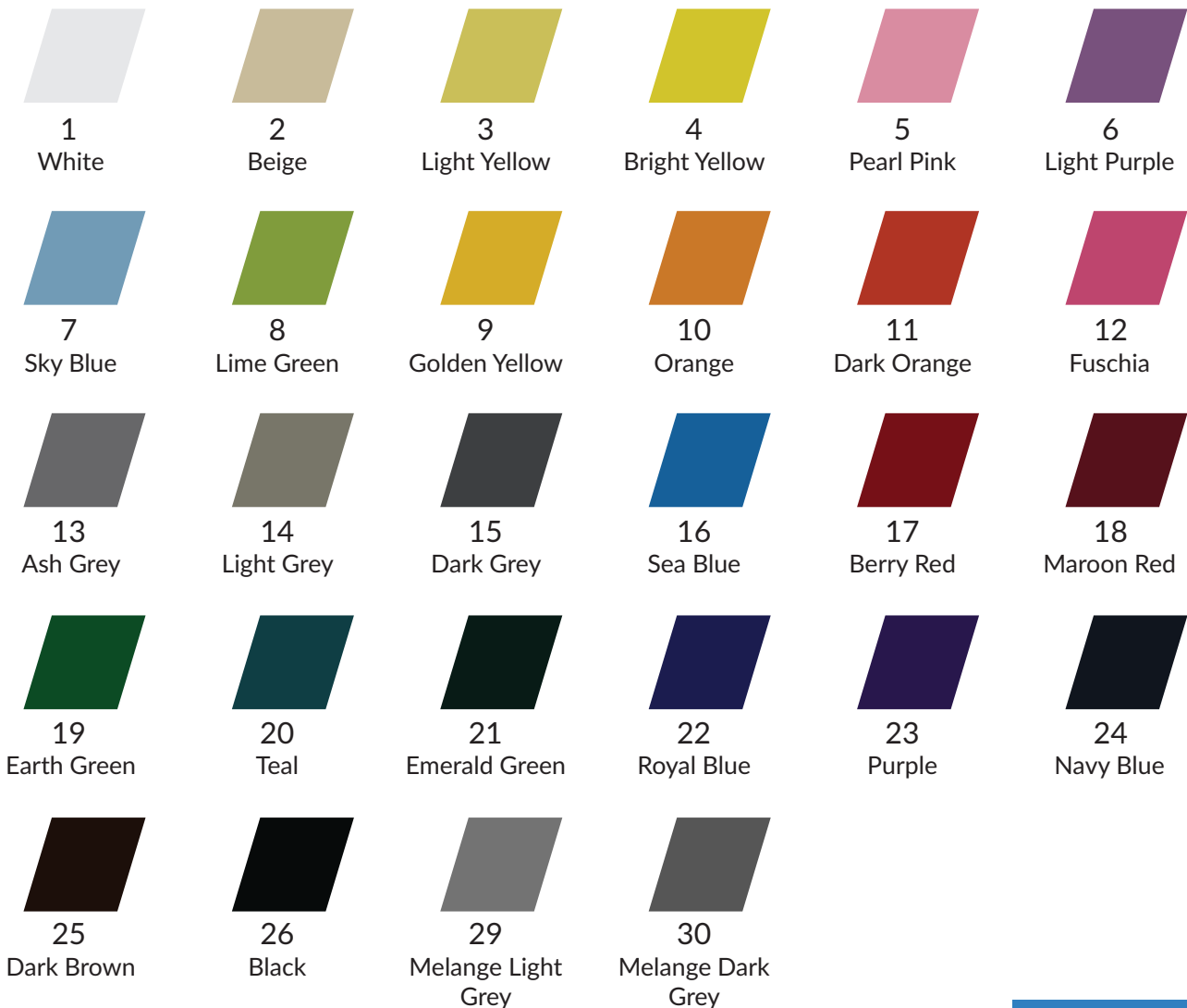

Polo Shirt

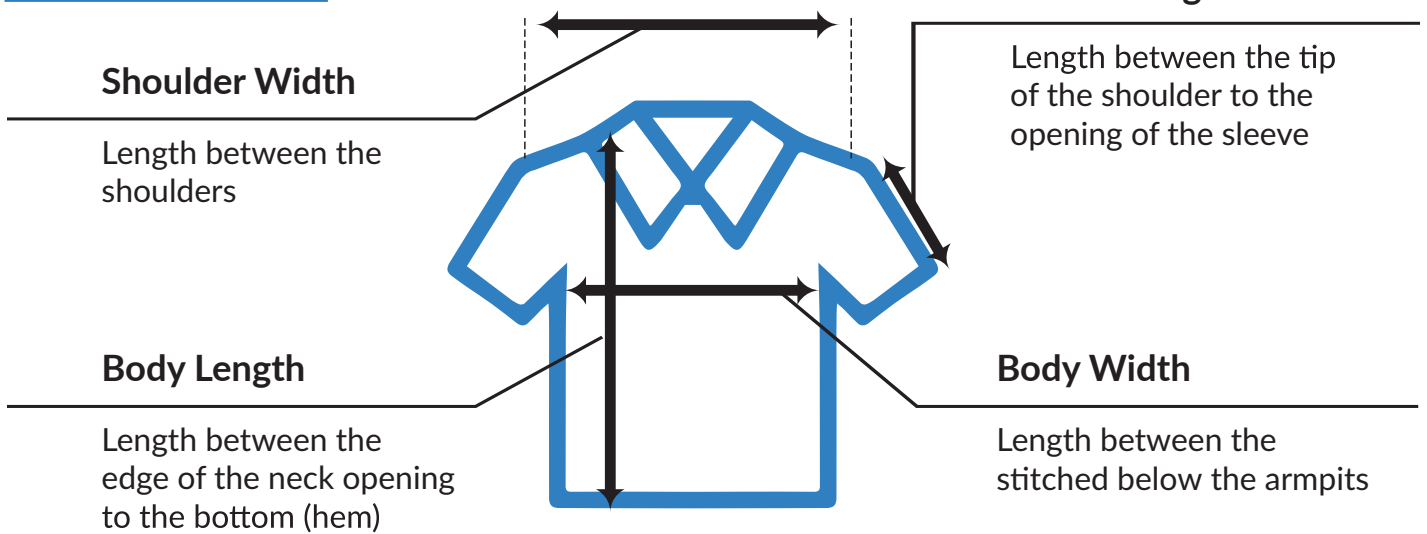

SKOLAH Clothing Guide

Primary Size Cutting

Measurement (inch)

Size	24	26	28	30	32	34	36	38
Shoulder	11	12	12 ^{1/2}	13	14	15	16	17
Chest	24	25 ^{1/2}	27 ^{1/2}	29	31	33	35	37
Body Length (Front)	16 ^{1/2}	17 ^{1/2}	18	20	21	22	23 ^{1/2}	26 ^{1/2}
Sleeve Length (Short)	5	5 ^{1/2}	6	6	6 ^{1/2}	6 ^{1/2}	7	7 ^{1/2}
Sleeve Length (Long)	14	14 ^{1/2}	15	15 ^{1/2}	16	17	18	19

Secondary Size Cutting

Measurement (inch)

Size	40/S	42/M	44/L	46/XL	48/2XL	50/3XL	52/4XL	54/5XL
Shoulder	17	18 ^{1/2}	19	20	21	21 ^{1/2}	23	24
Chest	39	41	43	45	47	48 ^{1/2}	50 ^{1/2}	52 ^{1/2}
Body Length	27	28	29 ^{1/2}	30	31	31 ^{1/2}	33	36
Sleeve Length (Short)	8	8 ^{1/2}	9	9 ^{1/2}	10	10	10 ^{1/2}	11 ^{1/2}
Sleeve Length (Long)	20	21	21 ^{1/2}	22	22 ^{1/2}	23 ^{1/2}	25	26

*Size might be different +/- 0.5 due to manual measurement

POLO SHIR





Short Pants

Material: TC Drill

- Polyester (65%), Cotton (35%)



























Primary size	20 - 33
--------------	---------

Easy Care

Crumple resistant

Lastig Colour

Least Sweat Absorbent

					
9500 Brilliant White	9501 Bright White	9001 Snow White	9002 Beige	9004 Khaki	9006 Dark Brown
					
9013 Light Grey	9005 Ash Grey	9007 Ash Grey	9010 Pewter	9011 Strata	9055 Slate Grey
					
9012 Deep Slate Grey	9074 Iron Grey	9020 Baby Blue	9018 Royal Blue	9008 Sky Blue	9014 Cobalt Blue
					
9009 Yale Blue	9030 Sea Blue	9019 Jungle Green	9017 Dark Slate Green	9567 Army Green	9606 Fern Green
					
		9607 Forest Green	9032 Mint Green	9003 Olive Green	



9610
Navy Blue



9620
Dark Navy Blue



9630
Deep Blue



9680
Black



9033
Lemon Yellow



9300
Mustard Yellow



9603
Dark Orange



9029
Bright Orange



9602
Cherry Red



9609
Maroon Red



9022
Earth Brown

Short Pant

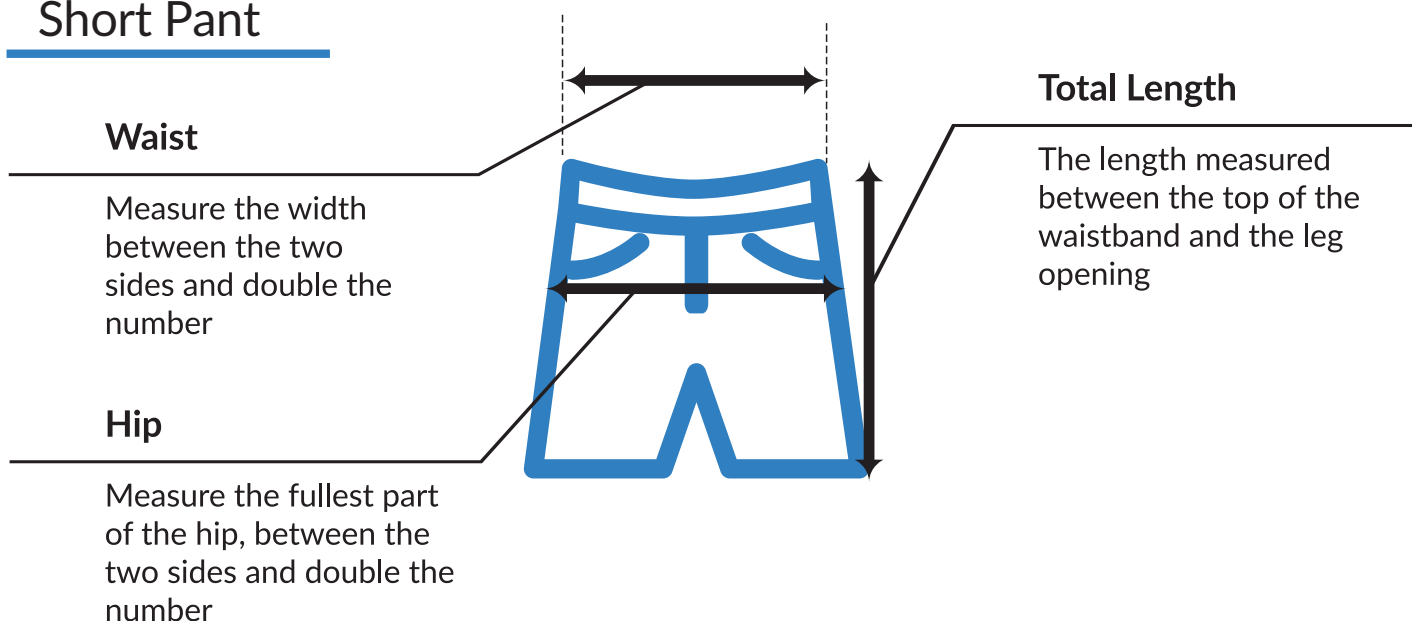

SKOLAH Clothing Guide

Primary Size Cutting

Measurement (inch)

Size	20	21	22	23	24	25	26
Waist Relax	20	21	22	23	24	25	26
Hip	25 ^{1/2}	25 ^{1/2}	26 ^{1/2}	26 ^{1/2}	27 ^{1/2}	27 ^{1/2}	28 ^{1/2}
Length Pant (Short)	14	15	16	17	18	19	20

Size	27	28	29	30	31	32	33
Waist Relax	28 ^{1/2}	29 ^{1/2}	29 ^{1/2}	30 ^{1/2}	30 ^{1/2}	31 ^{1/2}	31 ^{1/2}
Hip	28 ^{1/2}	29 ^{1/2}	29 ^{1/2}	30 ^{1/2}	30 ^{1/2}	31 ^{1/2}	31 ^{1/2}
Length Pant (Short)	21	22	23	24	25	26	27

*Size might be different +/- 0.5 due to manual measurement





Long Pants

Material: TC Drill

- Polyester (65%), Cotton (35%)

Primary size	20 - 33
Secondary size	24 - 38

Easy Care

Crumple resistant

Lastig Colour

Least Sweat Absorbent



9500
Brilliant White



9501
Bright White



9001
Snow White



9002
Beige



9004
Khaki



9006
Dark Brown



9013
Light Grey



9005
Ash Grey



9007
Ash Grey



9010
Pewter



9011
Strata



9055
Slate Grey



9012
Deep Slate Grey



9074
Iron Grey



9020
Baby Blue



9018
Royal Blue



9008
Sky Blue



9014
Cobalt Blue



9009
Yale Blue



9030
Sea Blue



9019
Jungle Green



9017
Dark Slate Green



9567
Army Green



9606
Fern Green



9607
Forest Green



9032
Mint Green



9003
Olive Green



9610
Navy Blue



9620
Dark Navy Blue



9630
Deep Blue



9680
Black



9033
Lemon Yellow



9300
Mustard Yellow



9603
Dark Orange



9029
Bright Orange



9602
Cherry Red



9609
Maroon Red



9022
Earth Brown

Long Pant

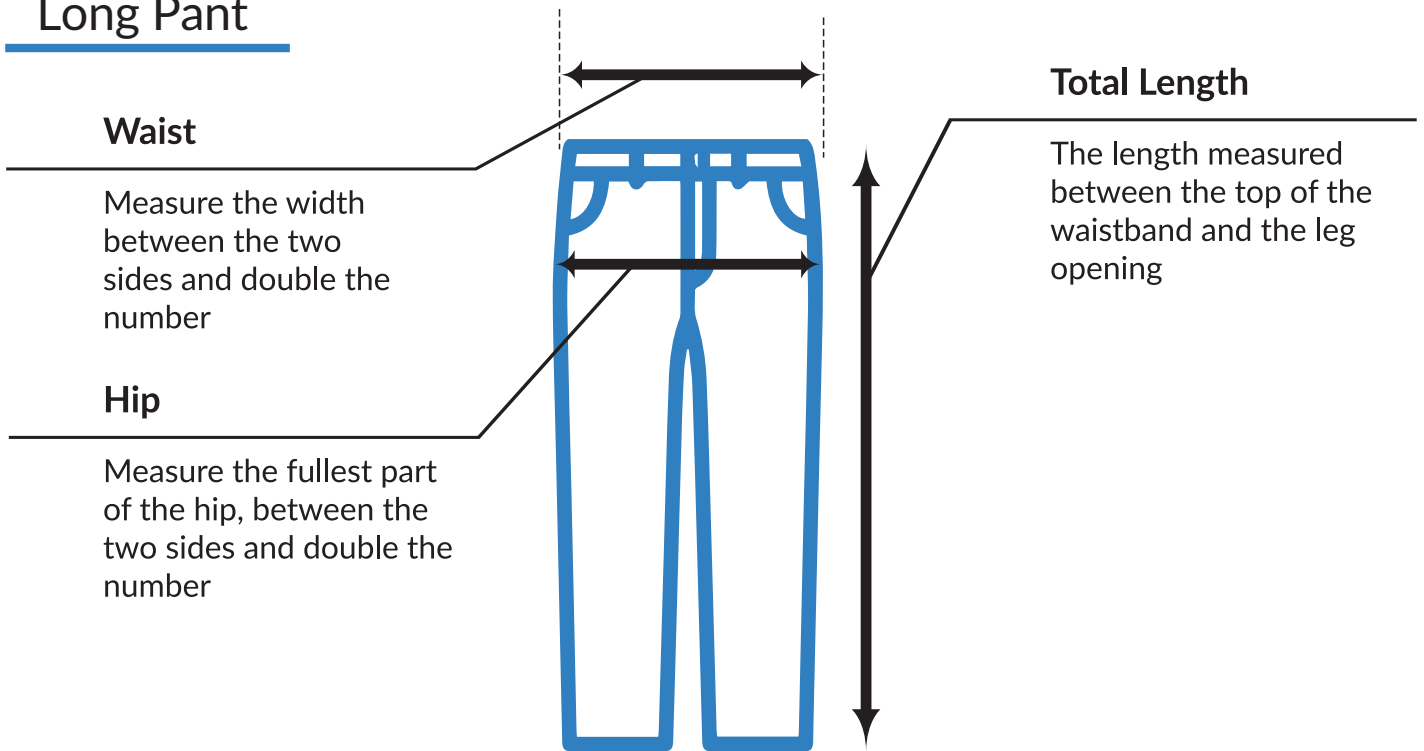

SKOLAH Clothing Guide

Primary Size Cutting

Measurement (inch)

Size	20	21	22	23	24	25	26	27	28	29	30	31	32	33
Waist Relax	20	21	22	23	24	25	26	28 ^{1/2}	29 ^{1/2}	29 ^{1/2}	30 ^{1/2}	30 ^{1/2}	31 ^{1/2}	31 ^{1/2}
Hip	25 ^{1/2}	25 ^{1/2}	26 ^{1/2}	26 ^{1/2}	27 ^{1/2}	27 ^{1/2}	28 ^{1/2}	28 ^{1/2}	29 ^{1/2}	29 ^{1/2}	30 ^{1/2}	30 ^{1/2}	31 ^{1/2}	31 ^{1/2}
Length Pant	24	26	28	30	32	33 ^{1/2}	35	36 ^{1/2}	38	38	38	38	38	38

Secondary Size Cutting

Measurement (inch)

Size	24	25	26	27	28	29	30	31	32	33	34	35	36	38
Waist Relax	24	25	26	27	28	29	30	31	32	33	34	35	36	38
Hip	35	36	37	38	39	40	41	42	43	44	45	46	47	49
Length Pant	36	37 ^{1/2}	38 ^{1/2}	39	40	40	40	40	40	40 ^{1/2}	40 ^{1/2}	40 ^{1/2}	41	41

*Size might be different +/- 0.5 due to manual measurement



Customized Process



Step 1 Draft Design

Design can be drafted from a professional using Adobe Illustrator or down to the simple using a pen and a paper. The purpose is just to visualize the idea.

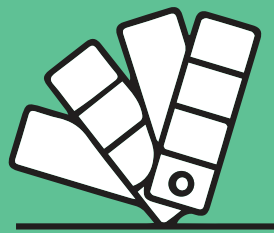

Step 2 Choose preferred

We have various different kind of fabric to choose from, or provide us with a sample that you would like the fabric to be like.



Step 3 Add on extra feature

Add on feature included embroidery, silk-screen printing, heat press or sublimation printing.

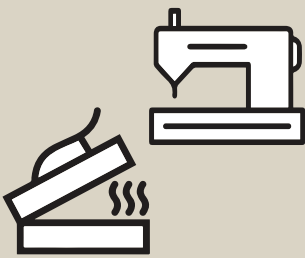

Step 4 Produce & Confirm

Once all information and artwork is gathered, a pre-production sample will be produced to ensure it looks as what our client request.



Step 5 Mass Production

Wait for the delivery.



SKOLAH

SECONDARY & PRIMARY

EDITION

FWS International Sdn Bhd (1031239-P)
No 15, Jalan Mutiara Raya, Taman Mutiara Barat, Cheras 57000
Kuala Lumpur, Malaysia.